

NORNDA AUTOMOTIVE

Assembly Instructions - Chrysler Valiant Slant 6

1 Standard Timing

Using keyway and tooth marked '0'

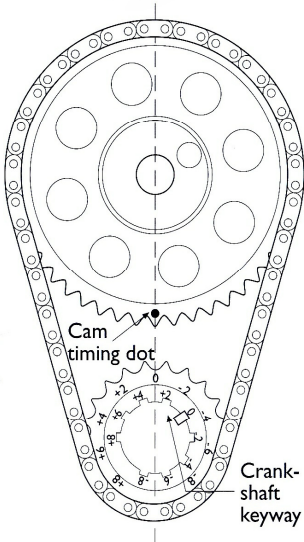

We recommend using a good service manual when installing new componentry

Warning: Do not use the keyway marks to time engine. Always align the crank gear tooth timing mark to cam gear timing mark.

Note: Check for clearance between timing chain and oil gallery boss. On some later blocks it may be necessary to remove material from the top side of the boss for chain clearance.

Lubrication: For maximum chain life, proper chain lubrication is necessary. When R.P.M. increases, chain lubrication must also increase. In order to reduce wear, a good lubricant must form a film over the contacting surfaces. Excessive wear can cause the chain to lengthen to the point of damaging sprocket teeth and destroying the timing chain.

2 Advanced Timing

(+2° +4° +6° +8°)

NOTE: We recommend to always degree-in the camshaft before making any timing changes. Use JP 5720 degree wheel.

1. Before assembly carefully inspect crankshaft sprocket. Note the position of each keyway on the inside diameter and the position of the equivalent timing mark on the outside gear tooth.
2. Fit the crankshaft sprocket to the crankshaft, ensuring that the keyway selected is aligned to the crankshaft keyway.
3. Rotate the crankshaft until the selected advance position on the outer sprocket is aligned with the timing mark on the camshaft sprocket.

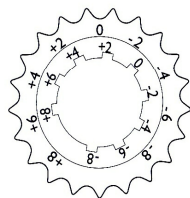

3 Retard Timing

(-2° -4° -6° -8°)

NOTE: We recommend to always degree-in the camshaft before making any timing changes. Use JP 5720 degree wheel.

1. Before assembly carefully inspect crankshaft sprocket. Note the position of each keyway on the inside diameter and the position of the equivalent timing mark on the outside gear tooth.
2. Fit the crankshaft sprocket to the crankshaft, ensuring that the keyway selected is aligned to the crankshaft keyway.
3. Rotate the crankshaft until the selected retard position on the outer sprocket is aligned with the timing mark on the camshaft sprocket.

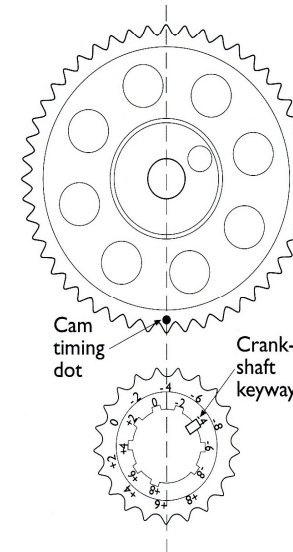

Nornda Pty Ltd
25-31 Innes Road,
Windsor Gardens
South Australia 5087
Tel: 61 8 8261 7222
Fax: 61 8 8261 9171

