

Assembly Instructions

Nornda Pty Ltd
25-31 Innes Road
Windsor Gardens
South Australia 5087
Ph: +61 8 8261 7222
Fx: +61 8 8261 9171

To Suit: V6 Buick

NOTE: Remove Balance Shaft before fitting

1 Standard Timing

Using keyway and tooth marked '0'

Warning: Do not use the keyway marks to time engine. Always align the crank gear tooth timing mark to cam gear timing mark.

Note: Check for clearance between timing chain and oil gallery boss. On some later blocks it may be necessary to remove material from the top side of the boss for chain clearance.

Lubrication: For maximum chain life proper chain lubrication is necessary. When RPM increases chain lubrication must also increase. In order to reduce wear, a good lubricant must form a film over the contacting surfaces. Excessive wear can cause the chain to lengthen to the point of damaging sprocket teeth and destroying the chain.

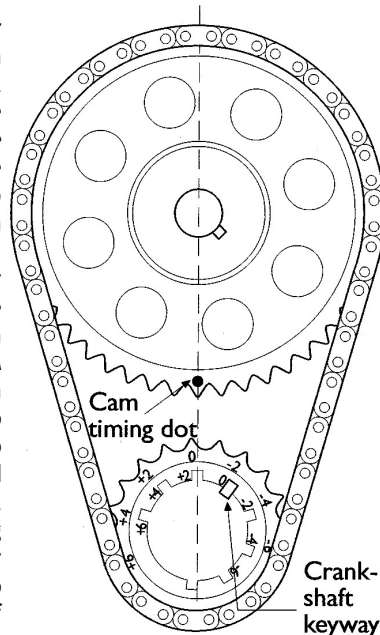

2 Advanced Timing

(+2° +4° +6°)

1. Before assembly carefully inspect the crankshaft sprocket. Note the position of each keyway on the inside diameter and the position of the equivalent timing mark on the outside gear tooth.

2. Fit the crankshaft sprocket to the crankshaft, ensuring that the keyway selected is aligned to the crankshaft keyway.

3. Rotate the crankshaft until the selected advance position on the outer sprocket is aligned with the timing mark on the camshaft sprocket.

We recommend to always degree-in the camshaft before making any timing changes. Use JP5720 degree wheel.

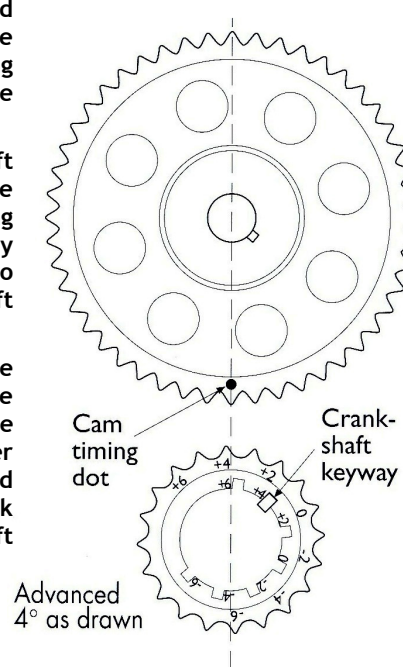

3 Retard Timing

(-2° -4° -6°)

1. Before assembly carefully inspect the crankshaft sprocket. Note the position of each keyway on the inside diameter and the position of the equivalent timing mark on the outside gear tooth.

2. Fit the crankshaft sprocket to the crankshaft, ensuring that the keyway selected is aligned to the crankshaft keyway.

3. Rotate the crankshaft until the selected retard position on the outer sprocket is aligned with the timing mark on the camshaft sprocket.

We recommend to always degree-in the camshaft before making any timing changes. Use JP5720 degree wheel.

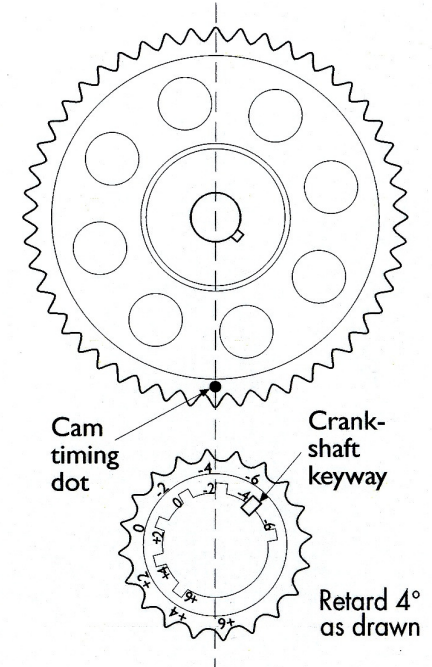

Nornda Automotive